



Zero Emission Electric Power Available

Collision avoidance system (CAS)

No Touch Protection: 3D Infrared sensor based system to ensure full IATA 913 Collision Avoidance Compliance

Low and zero emission ramp warrior.

The TC-888 Mobile Belt Loader continues to prove its durability on ramps around the globe. Now with low and zero emission power options it is the wisest choice for fleet modernization. Economical operations in a low maintenance reliable package for flawless turn, each and every time. The TC-888 has a 2,000 pound (907 kg) capacity at full incline. At only 47.5 inches (1.21 meters) high the TC-888 maneuvers easily around aircraft and other ramp equipment.

The TC-888 is available in electric, diesel, gasoline or LP power options.

Customized configurations for every application are available.



Photos and illustrations may show optional equipment.

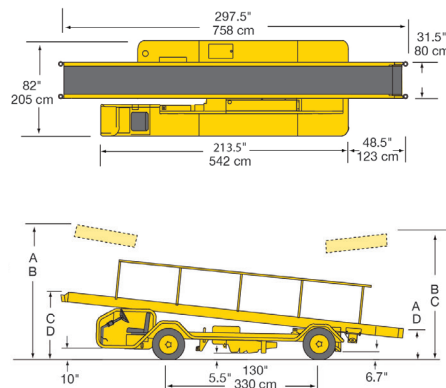

Features:

- ✓ Zero emission electric power
- ✓ Low emission Stage V and Tier 4 Final diesel power
- ✓ EPA approved gasoline or LP fuel
- ✓ Factory new automatic transmission
- ✓ Lightweight, fuel efficient, impact deflecting steel frame
- ✓ Four corner conveyor and E-Stop controls
- ✓ LED lighting
- ✓ Safety
 - Back up alarm
 - Horn
 - Anti-restart ignition switch
 - Engine safety shutdown (engine dependent; low oil pressure, high temperature)

TC-888 Mobile Belt Loader

	IMPERIAL	METRIC		IMPERIAL	METRIC
Aircraft servicing capabilities			Height of conveyor bed from ground*		
Doorsill height	42 – 167 in	107 – 424 cm	A – Front EXTENDED, Rear RETRACTED		
Dimensions			Front	167 in	4.24 m
Length	297.5 in	756 cm	Rear	14.5 in	0.37 m
Width	82 in	205 cm	Angle	33°	33°
Height	47.5 in	121 cm	B – Front EXTENDED, Rear EXTENDED		
Wheel Base	130 in	330 cm	Front	154.5 in	3.92 m
Conveyor Length	297.5 in	756 cm	Rear	41.5 in	1.05 m
Conveyor Width	31.5 in	80 cm	Angle	24°	24°
Conveyor Capacity at full incline	2,000 lbs	909 kg	C – Front RETRACTED, Rear EXTENDED		
Conveyor Speed	40-120 fpm	0.2-0.6m/sec	Front	28 in	0.71 m
Gross vehicle weight (non-electric)	+/- 5,900 lbs	+/- 2,676 kg	Rear	59 in	1.5 m
Turn Radius	22 ft	6.7 m	Angle	-6°	-6°
Speed			D – Front RETRACTED, Rear RETRACTED		
Max speed	25 mph	40 kph	Front	42 in	1.07 m
			Rear	33.5 in	0.85 m
			Angle	2°	2°

*Bed heights subject to change depending on engines and options selected.

Drive System

Engine options

Electric

- 80V AC with Curtis controller
- Lead- Acid or Lithium Battery
- Onboard charger available

Diesel

- Deutz D2.9L (available in Stage 5 and Tier 4 Final)
- Cummins B3.3 (Tier 3, export only)
- Deutz 2011 (Tier 3, export only)

Gasoline

- Kubota WG2503
- Ford MSG425

LP

- Kubota WG2503
- Ford MSG425

Cooling system

- Full size liquid cooled radiator, isolated from vibration

Transmission

- Factory new GM 4L70E automatic transmission with separate transmission fluid cooler, with shift abuse protection

Axles

- Front:** Brierton (standard), Comer (optional)
- Rear:** Dana (standard), Comer (optional)

Tires

- Front:** P225/75R15
- Rear:** P225/75R15

Systems

Chassis

- Lightweight, durable tubular impact deflecting frame

Steering

- Power assisted

Systems (cont.)

Braking

- Four wheel, split cylinder
- Front:** Disc
- Rear:** Drum
- Parking:** Drum with conveyor belt interlock

Instrumentation

- J1939 CAN gauge (Stage V, Tier 4 Final, gasoline and LP)
- LED warning indicators
- Alternator
- Engine oil pressure
- Coolant temperature
- Brakes
- Engine hour meter

Hydraulics

- Lift cylinders:** Single stage
- Valves: Manually activated
- Pump:** Engine driven
- Filter on return line:** 10 microns
- Strainer on suction line:** 80 mesh

Lighting (LED)

- Headlights
- Taillights
- Brake
- Reverse
- Work light

Electrical

- 12V
- Maintenance free battery
- 60 amp minimum alternator (engine dependent)

Configurations

Standard

- Retractable seat belt
- Engine cover
- Front and rear conveyor "D" bumpers

Configurations (cont.)

Standard (cont.)

- Right side collapsible hand rail system
- Engine safety shutdown (low oil pressure, high temperature)
- Back up alarm
- Anti-restart ignition switch
- 22 gallon (83 liter) fuel tank
- Zinc rich primer and white or safety yellow polyurethane top coat

Optional

- No Touch IATA 913 Compliant Collision Avoidance System
- Lithium battery (consult factory for details)
- Battery Management System for fast chargers
- On board SAE J1772 compliant charger
- Retractable left side package guide
- Third party handrail options
- Enclosed operators cab
- Canopy over conveyor belt
- Seat options
- Keyed ignition
- LED amber beacon light
- LED turn signals
- Push button start
- Rear view mirror
- Master disconnect switch
- Tow hooks
- Fire extinguisher(s)
- Spare tire assemblies
- Preventive maintenance service kits
- Heavy duty winterization package to -40F
- Custom paint color
- Consult factory for additional specialized configurations

Note: Dimensions may change slightly with individual engine packages. Specifications subject to change without notice.